



IBRA
SHOWERS

BOX DOCCIA
SHOWER ENCLOSURES
PAROIS DE DOUCHE

BEST pieghevole
> 6 mm

BEST
pieghevole

BEST PIEGHEVOLE

Caratteristiche / features / caractéristiques

- | | | |
|--|--|--|
| <ul style="list-style-type: none"> > H 200 cm > Chiusura a calamita inserita su profilo in alluminio > Profili gocciolatoi in PVC trasparente antigoccia > Profilo inferiore di contenimento acqua > Profili verticali dotati di tappi di chiusura trasparenti > Possibilità di fuori misura > Montaggio rapido > Pomolo di serie > Soffietto privo di guida > Cerniera di snodo apribile solamente verso l'esterno per facilitare l'apertura dell'anta pieghevole | <ul style="list-style-type: none"> > H 200 cm > Magnetic closing system inserted in the aluminium seal > Drip sealing strips in transparent PVC anti-mould > Water containment profile > Transparent upper covers for the adjustment profile > Out of standard on request > Easy to assemble > Standard knob > Bellows opening without guide rail > Joint hinge that can be opened only outwards to facilitate opening of the folding door | <ul style="list-style-type: none"> > H 200 cm > Fermeture magnetique inserée dans le profil en aluminium > Profils en PVC contre l'éclaboussement > Profils inferieur pour le confinement de l'eau > Profils verticaux avec bouchons de fermeture transparents > Hors standard sur demande > Assemblage rapide > Bouton de série > Porte-accordeo sans guides > Charnière de jonction qui ne peut être ouverte que vers l'extérieur pour faciliter l'ouverture de la porte pliante |
|--|--|--|

Vetri / glasses / verre



00 Trasparente GE Grigio Europa SA Satinato BZ Bronzo

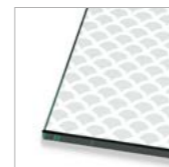

X2-X3-X4-X5 Serigrafie (v. pag. 95)
Serigraphies (see page 95)
Sérigraphies (voir page 95)

Profili / profiles / profils

STANDARD:

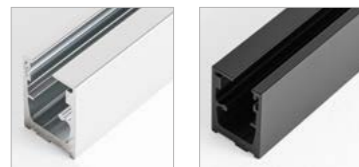

B Brill N Nero

SPECIAL:



9 Laccato
Lacquered
Laqué

BEST PIEGHEVOLE - MANIGLIE



BEST

- pomolo di serie**
as standard
de série
- > **Fissata sul vetro**
> Fixed to the glass
> Fixée au verre



TI orizzontale

- alternativa (specificare nell'ordine)**
optional (to specify in the order)
alternative (indiquer dans la commande)
- > **Fissata sul vetro**
> Fixed to the glass
> Fixée au verre

- > **Sovraprezzo:**
- > Surcharge:
- > Supplément:

BEST PIEGHEVOLE - TECHNICS

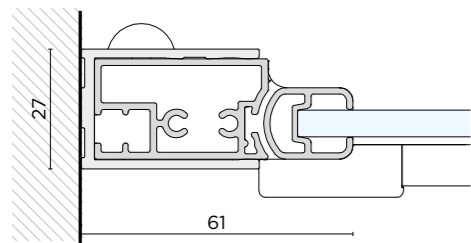

Fissaggio a muro

Wall mounting
Fixation au mur

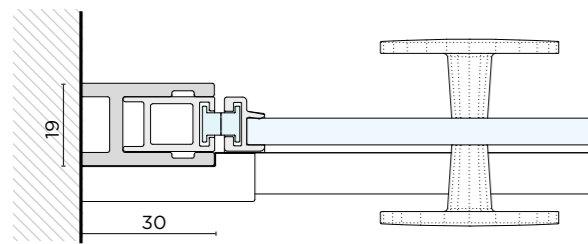

Battuta della porta pieghevole in nicchia

Abutment of the bi-fold door in a niche
Butée de la porte pliante en niche

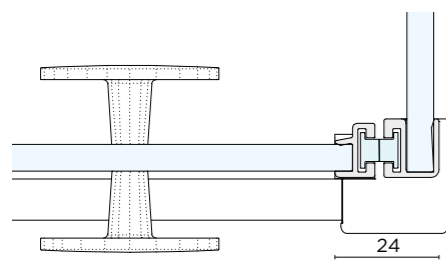

Battuta della porta pieghevole con fisso laterale

Abutment of the bi-fold door with fixed panel
Butée de la porte pliante avec coté fixe latéral

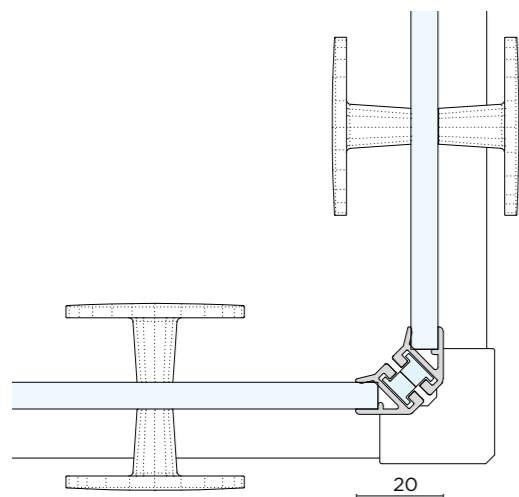

Angolo con due porte scorrevoli

Corner with two sliding bi-fold doors
Angle avec 2 portes pliantes

BEST PIEGHEVOLE

Configurazioni / configurations / configurations

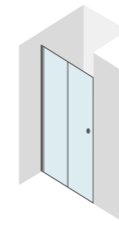

NICCHIA > 1 porta

1 door

1 porte

p.84

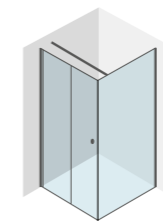

ANGOLO > 1 porta

1 door

1 porte

p.86

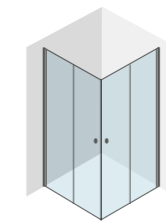

ANGOLO > 2 porte

2 doors

2 portes

p.88

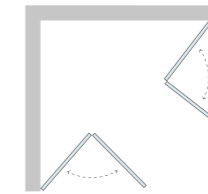
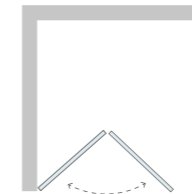
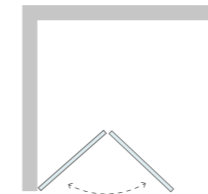

BEST: **PIEGHEVOLE** **BI-FOLD DOOR** **PLIANTE**

LEGENDA KEY / LÉGENDE

F fisso / fixed panel / côté fixe
L lato / fixed lateral panel / côté fixe latéral
A apertura / opening / entrée
P porta / door / porte

BEST **PIEGHEVOLE**

Configurazioni / configurations / configurations

Di serie:
Standard:
De série:



NICCHIA
> 1 porta

1 door

1 porte



ANGOLO
> 1 porta

1 door

1 porte



ANGOLO
> 2 porte

2 doors

2 portes

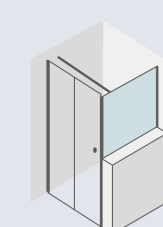

SOPRA MURETTO
> Fisso laterale

Fixed lateral panel
over a wall

Côté fixe latéral sur
le mur

A richiesta
(contattare ufficio
tecnico):
On request
(to be verified
with technical
department):
Sur demande
(vérifier avec
le département
technique):



LATO COLONNA
> Pieghevole lato
colonna + fisso laterale

Bi-fold door + fixed
lateral panel

Porte pliante + côté fixe
latéral

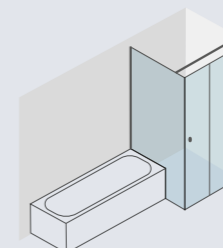

SAGOMATO
> Pieghevole + fisso
laterale sagomato

Bi-fold door + shaped
fixed lateral panel

Porte pliante + paroi fixe
latérale façonnée

Dettagli / details / détails



Cerniera integrata:
La cerniera è integrata nel profilo montante, per garantire una grande apertura utile.

Integrated hinge:
The hinge is integrated in the vertical profile to maximize the opening.

Charnière intégrée:
La charnière est intégrée dans le profilé vertical pour permettre un passage maximal.



Cerniera di snodo:
La cerniera è apribile solamente verso l'esterno per facilitare l'apertura dell'anta pieghevole.

Joint hinge:
the hinge can be opened only outwards to facilitate opening of the folding door

Charnière de jonction:
la charnière peut ouverte seulement vers l'extérieur pour faciliter l'ouverture de la porte pliante



Profilo inferiore di barriera:
ha un design discreto e assicura la perfetta tenuta dell'acqua

Lower barrier profile:
it has a minimalist design that assure a good water tightness.

Profilé inférieur de barrière:
il a un design discret et il assure une étanchéité parfaite

01.

**Porta pieghevole
angolo + lato fisso**
nero + vetro grigio europa

*Bi-fold door + fixed panel
in corner*
in nero + grigio europa glass

*Porte pliante + côté fixe
en coin*
nero + verre grigio europa

Piatto doccia:
Synthesis Bianco
L 90 x P 70 cm

Shower tray:
Synthesis Bianco
W 90 x D70 cm

Receveur:
Synthesis Bianco
L 90 x P 70 cm





cerniera minimale della stessa finitura del box doccia:
apertura esterna per facilitare la movimentazione del soffietto

minimal hinge matched with the shower enclosure:
outwards opening to easier the movement

charnière minimaliste assortie au profilé de la parois de douche:
ouverture vers l'extérieur pour faciliter le mouvement du soufflet



l'impacchettamento della porta è totale:
ottimo per soluzioni dove gli spazi sono ridotti

The folding door
is the perfect solution where spaces are reduced

L'empaquetage de la porte est totale:
c'est parfait pour des endroits étroits

02.

**Porta pieghevole
nicchia**
brill + vetro trasparente

*Bi-fold door
in niche
in brill + trasparente glass*

**Porte pliante
en niche**
brill + verre transparente

Piatto doccia:
Arya Bianco
L 90 x P 90 cm

Shower tray:
Arya Bianco
W 90 x D 90 cm

Receveur:
Arya Bianco
L 90 x P 90 cm





Pomolo cromato
interno ed esterno
per un'apertura
facilitata

Knob chrome
inside and outside
for an easy
opening

Bouton chrome
à l'intérieur
et à l'extérieur pour
une ouverture aisée



BEST PIEGHEVOLE

Nicchia
Niche
Niche

Porta pieghevole
Bi-fold door
Porte pliante

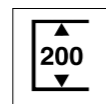

Altezza 200 cm
Height 200 cm
Hauteur 200 cm

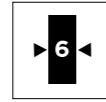

Vetro sp. 6 mm
Glass th. 6 mm
Verre ép. 6 mm



Fuori misura:
altezza max 210 cm / larghezza max 100 cm
Out of standard:
height max. 210 cm / width max. 100 cm
Sur demande:
hauteur max. 210 cm / largeur max. 100 cm

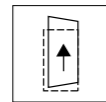

Cerniera con sollevamento in apertura
Hinge with lifting mechanism while opening
Charnière avec mécanisme de levage pendant l'ouverture

Configurazioni:
Configurations:
Configurations:

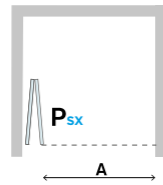

VERSIONE SX
Left
Gauche

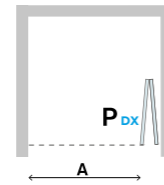

VERSIONE DX
Right
Droite

MAGGIORAZIONI / SURCHARGE / SUPPLÉMENT

Fuori Misura:
Out of standard:
Sur mesure:



(richiedere fattibilità)
(ask for feasibility)
(vérifier la faisabilité avec le service technique)

Vetro con serigrafie:
Serigraphies (see page 95):
Sérigraphies (voir page 95):



maggiorazione dal TRASPARENTE
increase on the TRASPARENTE price
à appliquer sur le prix du TRASPARENTE

Trattamento anticalcare:
Glass treatment:
Traitement verre:



Lato
Side
Verre

BEST PIEGHEVOLE

Nicchia
Niche
Niche

Porta pieghevole
Bi-fold door
Porte pliante

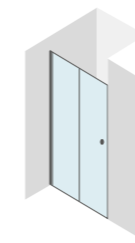

ATTENZIONE
Specificare il verso al momento dell'ordine.

ATTENTION
Indicate the side in the order.

ATTENTION
Indiquer le vers dans la commande.

P - PORTA PIEGHEVOLE / BI-FOLD DOOR / PORTE PLIANTE

ART. ITEM ART.	ESTENSIBILITÀ EXTENSIBILITY EXTENSIBILITÉ	PIATTO TRAY RECEVEUR	APERTURA OPENING ENTRÉE	PROFILO / PROFILE / PROFIL			
				BRILL / NERO		COLORATO	
				VETRI / GLASS / VERRE			
				○	●	○	●
D6LP100	66 - 69	70	54				
D6LP105	71 - 74	75	59				
D6LP110	76 - 79	80	64				
D6LP115	81 - 84	85	69				
D6LP120	86 - 89	90	74				
D6LP125	91 - 94	95	79				
D6LP130	96 - 99	100	84				

VETRI / GLASS / VERRE

○ TRASPARENTE

● BRONZO | SATINATO | GRIGIO EUROPA

BEST PIEGHEVOLE

Angolo
Corner
Coin

Porta pieghevole + fisso laterale
Bi-fold door + fixed lateral panel
Porte pliante + côté fixe latéral

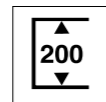

Altezza 200 cm
Height 200 cm
Hauteur 200 cm

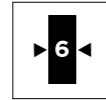

Vetro sp. 6 mm
Glass th. 6 mm
Verre ép. 6 mm



Fuori misura:
altezza max 210 cm / larghezza max 100 cm / profondità max 120 cm
Out of standard:
height max. 210 cm / width max. 100 cm / depth max. 120 cm
Sur demande:
hauteur max. 210 cm / largeur max. 100 cm / profondeur max. 120 cm



Braccetto (A) accorciabile in opera compreso nel prezzo
Stabilizing bar (A) to be cutted during installation included
Barre de soutien (A) à couper en cours de réalisation comprise dans le prix.

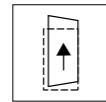

Cerniera con sollevamento in apertura
Hinge with lifting mechanism while opening
Charnière avec mécanisme de levage pendant l'ouverture

Configurazioni:
Configurations:
Configurations:

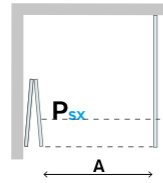

VERSIONE SX
Left
Gauche

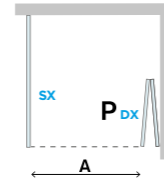

VERSIONE DX
Right
Droite

MAGGIORAZIONI / SURCHARGE / SUPPLÉMENT

Fuori Misura:
Out of standard:
Sur mesure:



(richiedere fattibilità)
(ask for feasibility)
(vérifier la faisabilité avec le service technique)

Vetro con serigrafie:
Serigraphies (see page 95):
Sérigraphies (voir page 95):



maggiorazione dal TRASPARENTE
increase on the TRASPARENTE price
à appliquer sur le prix du TRASPARENTE

Trattamento anticalcare:
Glass treatment:
Traitement verre:



Lato
Side
Verre

BEST PIEGHEVOLE

Angolo
Corner
Coin

Porta pieghevole + fisso laterale
Bi-fold door + fixed lateral panel
Porte pliante + côté fixe latéral

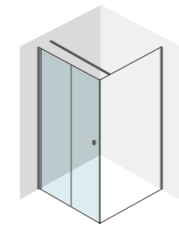

ATTENZIONE
Specificare il verso al momento dell'ordine.

ATTENTION
Indicate the side in the order.

ATTENTION
Indiquer le vers dans la commande.

P - PORTA PIEGHEVOLE / BI-FOLD DOOR / PORTE PLIANTE

ART. ITEM ART.	ESTENSIBILITÀ EXTENSIBILITY EXTENSIBILITÉ	PIATTO TRAY RECEVEUR	APERTURA OPENING ENTRÉE	PROFILO / PROFILE / PROFIL			
				BRILL / NERO	COLORATO		
				VETRI / GLASS / VERRE			
				○	●	○	●
D6LP200	67,5 - 69,5	70	56				
D6LP205	72,5 - 74,5	75	61				
D6LP210	77,5 - 79,5	80	66				
D6LP215	82,5 - 84,5	85	71				
D6LP220	87,5 - 89,5	90	76				
D6LP225	92,5 - 94,5	95	81				
D6LP230	97,5 - 99,5	100	86				

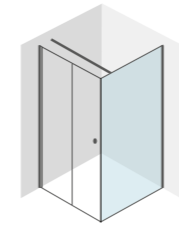

ATTENZIONE
Specificare il verso al momento dell'ordine.

ATTENTION
Indicate the side in the order.

ATTENTION
Indiquer le vers dans la commande.

L - FISSO / FIXED LATERAL PANEL / CÔTÉ FIXE LATÉRAL

ART. ITEM ART.	ESTENSIBILITÀ EXTENSIBILITY EXTENSIBILITÉ	PIATTO TRAY RECEVEUR	PROFILO / PROFILE / PROFIL			
			BRILL	NERO	COLORATO	
			VETRI / GLASS / VERRE			
			○	●	○	●
D6LA500	67,5 - 69,5	70				
D6LA505	72,5 - 74,5	75				
D6LA510	77,5 - 79,5	80				
D6LA515	82,5 - 84,5	85				
D6LA520	87,5 - 89,5	90				
D6LA525	92,5 - 94,5	95				
D6LA530	97,5 - 99,5	100				

VETRI / GLASS / VERRE

○ TRASPARENTE

● BRONZO | SATINATO | GRIGIO EUROPA

BEST PIEGHEVOLE

Angolo
Corner
Coin

2 porte pieghevoli
2 bi-fold doors
2 portes pliantes

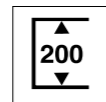

Altezza 200 cm
Height 200 cm
Hauteur 200 cm

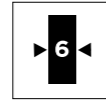

Vetro sp. 6 mm
Glass th. 6 mm
Verre ép. 6 mm



Fuori misura:
altezza max 210 cm / larghezza max 100 cm
Out of standard:
height max. 210 cm / width max. 100 cm
Sur demande:
hauteur max. 210 cm / largeur max. 100 cm

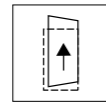

Cerniera con sollevamento in apertura
Hinge with lifting mechanism while opening
Charnière avec mécanisme de levage pendant l'ouverture

Configurazioni:
Configurations:
Configurations:

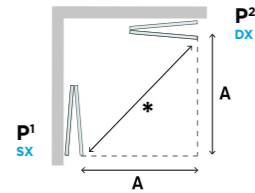

VERSIONE SX / DX
Left / Right
Gauche / Droite

MAGGIORAZIONI / SURCHARGE / SUPPLÉMENT

Fuori Misura:
Out of standard:
Sur mesure:



(richiedere fattibilità)
(ask for feasibility)
(vérifier la faisabilité avec le service technique)

Vetro con serigrafie:
Serigraphies (see page 95):
Sérigraphies (voir page 95):



maggiorazione dal TRASPARENTE
increase on the TRASPARENTE price
à appliquer sur le prix du TRASPARENTE

Trattamento anticalcare:
Glass treatment:
Traitement verre:



Lato
Side
Verre

BEST PIEGHEVOLE

Angolo
Corner
Coin

2 porte pieghevoli
2 bi-fold doors
2 portes pliantes



ATTENZIONE
Specificare il verso al momento dell'ordine.

ATTENTION
Indicate the side in the order.

ATTENTION
Indiquer le vers dans la commande.

P1 / P2 - PORTA PIEGHEVOLE / BI-FOLD DOOR / PORTE PLIANTE

ART. ITEM ART.	ESTENSIBILITÀ EXTENSIBILITY EXTENSIBILITÉ	PIATTO TRAY RECEVEUR	APERTURA OPENING ENTRÉE	PROFILO / PROFILE / PROFIL			
				BRILL / NERO		COLORATO	
				VETRI / GLASS / VERRE			
				○	●	○	●
D6LP300	67,5 - 69,5	70	56				
D6LP305	72,5 - 74,5	75	61				
D6LP310	77,5 - 79,5	80	66				
D6LP315	82,5 - 84,5	85	71				
D6LP320	87,5 - 89,5	90	76				
D6LP325	92,5 - 94,5	95	81				
D6LP330	97,5 - 99,5	100	86				

VETRI / GLASS / VERRE

○ TRASPARENTE

● BRONZO | SATINATO | GRIGIO EUROPA

ATTENZIONE!

Per il calcolo del prezzo totale vanno sommati 2 lati.

ATTENTION!

The total price is given by the addition of 2 sides.

ATTENTION!

Le prix total est donné par l'addition des 2 côtés.

DIMENSIONI APERTURA (*):
ENTRANCE DIMENSIONS (*):
DIMENSIONS DE PASSAGE (*):

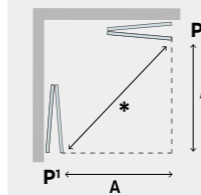

	70	75	80	85	90	95	100			
70	79	82	86	90	94	98	102			
75	82	86	89	93	97	101	105			
80	86	89	93	96	100	104	108			
85	90	93	96	100	104	107	111			
90	94	97	100	104	107	111	114			
95	98	101	104	107	111	114	118			
100	102	105	108	111	114	118	121			

SOPRAMURETTO

Angolo
Corner
Coin

Fisso laterale
Fixed lateral panel
Côté fixe latéral

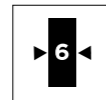

Vetro sp. 6 mm
Glass th. 6 mm
Verre ép. 6 mm



Fuori misura:
altezza max 150 cm / larghezza max 120 cm
Out of standard:
height max. 150 cm / width max. 120 cm
Sur demande:
hauteur max. 150 cm / largeur max. 120 cm

Configurazioni:
Configurations:
Configurations:

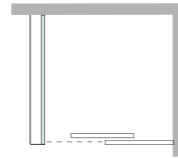

VERSIONE SX
Left
Gauche

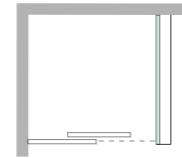

VERSIONE DX
Right
Droite

MAGGIORAZIONI / SURCHARGE / SUPPLÉMENT

Fuori Misura:
Out of standard:
Sur mesure:



(richiedere fattibilità)
(ask for feasibility)
(vérifier la faisabilité avec le service technique)

Vetro con serigrafie:
Serigraphies (see page 95):
Sérigraphies (voir page 95):



maggiorazione dal TRASPARENTE
increase on the TRASPARENTE price
à appliquer sur le prix du TRASPARENTE

Trattamento anticalcare:
Glass treatment:
Traitement verre:



Lato
Side
Verre

SOPRAMURETTO

Angolo
Corner
Coin

Fisso laterale
Fixed lateral panel
Côté fixe latéral

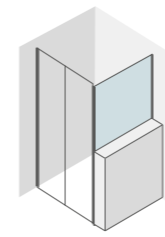

L - FISSO / FIXED LATERAL PANEL / CÔTÉ FIXE LATÉRAL

ART. ITEM ART.	ESTENSIBILITÀ EXTENSIBILITY EXTENSIBILITÉ	PROFILO / PROFILE / PROFIL			
		BRILL / NERO		COLORATO	
		VETRI / GLASS / VERRE			
		<input type="radio"/>	<input checked="" type="radio"/>	<input type="radio"/>	<input checked="" type="radio"/>
D6SM100	20 - 70				
D6SM105	71 - 90				
D6SM110	91 - 120				

ATTENZIONE
Specificare il verso al
momento dell'ordine.

ATTENTION
Indicate the side in the
order.

ATTENTION
Indiquer le vers dans la
commande.

VETRI / GLASS / VERRE

TRASPARENTE

BRONZO | SATINATO | GRIGIO EUROPA

SOPRAVASCA 4

Angolo
Corner
Coin

Porta pieghevole
Bi-fold door
Porte pliante

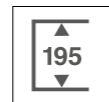

Altezza 140 cm
Height 140 cm
Hauteur 140 cm

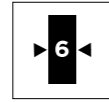

Vetro sp. 6 mm
Glass th. 6 mm
Verre ép. 6 mm

Configurazioni:
Configurations:
Configurations:

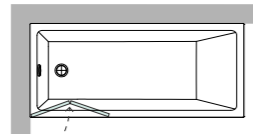

VERSIONE SX
Left
Gauche

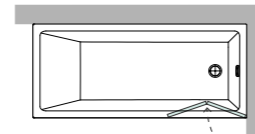

VERSIONE DX
Right
Droite

MAGGIORAZIONI / SURCHARGE / SUPPLÉMENT

Fuori Misura:
Out of standard:
Sur mesure:



(richiedere fattibilità)
(ask for feasibility)
(vérifier la faisabilité avec le service technique)

Vetro con serigrafie:
Serigraphies (see page 95):
Sérigraphies (voir page 95):



maggiorazione dal TRASPARENTE
increase on the TRASPARENTE price
à appliquer sur le prix du TRASPARENTE

Trattamento anticalcare:
Glass treatment:
Traitement verre:



Lato
Side
Verre

SOPRAVASCA 4

Angolo
Corner
Coin

Porta pieghevole
Bi-fold door
Porte pliante

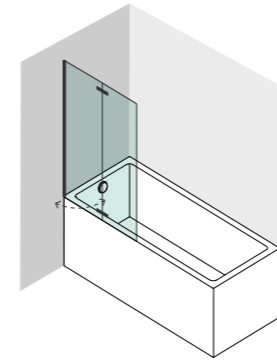

P - PORTA PIEGHEVOLE / BU-FOLD DOOR / PORTE PLIANTE

ATTENZIONE
Specificare il verso al momento dell'ordine.

ATTENTION
Indicate the side in the order.

ATTENTION
Indiquer le vers dans la commande.

ART. ITEM ART.	ESTENSIBILITÀ EXTENSIBILITY EXTENSIBILITÉ	PROFILO / PROFILE / PROFIL			
		BRILL / NERO		COLORATO	
		VETRI / GLASS / VERRE			
		<input type="radio"/>	<input checked="" type="radio"/>	<input type="radio"/>	<input checked="" type="radio"/>
D6PS100	92,5 - 99,5				
D6PS105	117,5 - 119,5				

VETRI / GLASS / VERRE

TRASPARENTE

BRONZO | SATINATO | GRIGIO EUROPA