



IBRA
SHOWERS

*PIATTI DOCCIA
SHOWER TRAYS
RECEVEURS DE DOUCHE*

SYNTHESIS

> *TEKORSTONE*
> *2 cm*





**Cover in acciaio
verniciato in tinta
di serie**

Lacquered stainless steel
plug cover in the same
finish as standard

Cache-bonde en
acier laqué assorti
de série





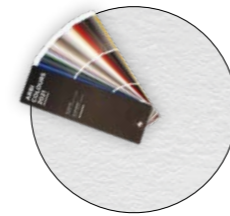

Bianco + 50 colori del piatto doccia Synthesis abbinabili ai profili dei box doccia.

Bianco + 50 colours for Synthesis shower tray matching with showers enclosures profiles.

Bianco + 50 finitions du receveur de douche Synthesis assorties aux profilés des parois de douche.

					
Petrolio	Blu Provenza	Bluriva	Blu Lapponia	Grigio Bromo	Mercurio
					
Verde Comodoro	Grigio Baltico	Verde Libano	Salice	Verde Oliva	Tè Verde
					
Shy	Ceruleo	Glicine	Dahlia	Blush	Corda
					
Brezza	Sambuco	Juta	Burro	Stone	Castoro Ottawa
					
Creta	Grigio Londra	Cenere	Grigio Manhattan	Grigio Efeso	Ghiaccio
					
New Pergamon	Petalò	Spring	Skin	Tan Pink	Cachi
					
Rosso Lacca	Rosso Fuoco	Rosso Rubino	Rosso Casale	Cacao	Terra
					
Carruba	Nero	Londra 2021	Grigio Rabbit	Lavagna	Eiffel
					
Dust	Polline				

SYNTHESIS

Caratteristiche / features / caractéristiques

> Made in Italy	> Made in Italy	> Fabriqué en Italie
> Tekorstone® texturizzato sia sulla superficie sia sul bordo del piatto	> Tekorstone® finish texturized on both the surface and the edges of the shower tray	> Finition Tekorstone® sur la surface du receveur et sur les bords
> Possibilità di installazione sia in appoggio che a filo pavimento	> Possibility of installation both on floor level or resting on the floor	> Possibilité d'installation soit posé au sol soit au ras du sol
> Facile da pulire	> Easy to clean	> Facile à nettoyer
> Antibatterico, antiscivolo e antigoccia	> Antibacterial, anti-slip and anti-drop	> Antibactérien, antidérapant et hydrofuges
> Facilmente lavorabile	> Easily workable	> Facile à couper
> Ripristinabile	> Restorable	> Peut être facilement restauré.
> Spessore ridotto di 2 cm	> Reduced thickness of 2 cm	> Épaisseur réduite de 2 cm
> Disponibile in dimensioni e forme sia di serie, che su misura	> Available in sizes and shapes as standard, or tailor-made	> Disponible en dimensions et formes de série, ou réalisable sur mesure
> La piletta e il copripiletta sono di serie	> The plug and the plug-cover are standard	> La bonde et le cache-bonde sont de série

Materiale / material / matériau

Tekorstone® è un materiale composto prodotto in Italia. La sua massa interna è costituita dalla combinazione di un materiale naturale e una resina poliestere mentre la superficie è rivestita da uno smalto tecnico effetto pietra. Tekorstone® è igienico e facile da pulire con panno morbido ed acqua. Nel caso l'installazione richiedesse tagli particolari, dovuti a scansi, pilastri e sporgenze, essendo un materiale facilmente lavorabile si può tagliare con normali utensili diamantati.

Tekorstone® is a composite material produced in Italy. Its internal mass consists of the combination of a natural material and a polyester resin while the surface is coated with a stone effect technical polish. Tekorstone® is hygienic and easy to clean, its surface can be cleaned with a soft cloth and water. If the installation requires special cuts, due to dodges, pillars and projections, being a material easily workable, it can be cut with normal diamond tools.

Tekorstone® est un matériel composite produit en Italie. Sa partie interne est composée par un mélange d'un matériau naturel et une résine polyester alors que la surface est revêtue d'un émail technique effet pierre. Tekorstone® est hygiénique et facile à nettoyer, sa surface peut être nettoyée avec un chiffon souple et de l'eau. Si l'installation nécessite des coupes spéciales, en raison des piliers et des saillies, il peut être coupé facilement avec des normaux outils diamantés.

Manutenzione / maintenance / entretien

Per rimuovere la maggior parte delle macchie, il calcare e lo sporco che normalmente si depositano sulla superficie è sufficiente pulire con acqua saponata o comuni detergenti e un panno morbido. Risciacquate bene la superficie e asciugate con un panno morbido. Il piatto Synthesis è resistente e durevole, ma può essere danneggiato se utilizzato in modo improprio, in quel caso è possibile un ripristino utilizzando il kit apposito (vedi pag. 154).

To remove most of the stains, limescale and dirt that normally deposit on the surface, clean with soapy water or common detergents and a soft cloth. Rinse the surface well, then dry with a soft cloth. The Synthesis shower tray is lasting, but it can be damaged if used improperly: in this case a reset is possible using the proper kit (see page 154).

Pour éliminer la plupart des taches, du calcaire et de la saleté qui se déposent normalement sur la surface, nettoyez simplement avec de l'eau savonneuse ou des détergents communs et un chiffon souple. Rincez bien la surface et séchez-la avec un chiffon souple. Le receveur de douche Synthesis est résistant et durable, mais il peut être endommagé s'il est utilisé en manière incorrecte. Dans ce cas vous pouvez le réparer en utilisant le kit de réparation approprié (voir page 154).

SYNTHESIS

Finiture Tekorstone Synthesis / Synthesis Tekorstone finishes / Finitions Tekorstone Synthesis

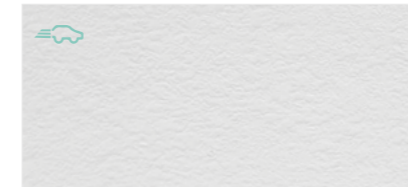

ES bianco



50 colori della mazzetta Arbi

Cover / plug cover / cache-bonde



DI SERIE

- > cod. AA82
- > Acciaio verniciato in tinta

STANDARD

- > cod. AA82
- > Matched lacquered stainless steel

DE SÉRIE

- > cod. AA82
- > Acier laqué assorti

Piletta di serie / standard plug / bonde de série



> cod. AA80

- > Sifonata
- > Ispezionabile
- > Portata d'acqua: 25 l/min
- > Utilizzo esclusivo per modello Synthesis

> cod. AA80

- > Siphoned
- > Inspectable
- > Water flow: 25 l/min
- > To be used for Synthesis model only

> cod. AA80

- > Siphonnée
- > Inspectionnable
- Quantité d'eau: 25 l/min
- > À utiliser exclusivement pour le modèle Synthesis

Disegno indicativo per pozzetto / indicative drawing for pit / dessin indicatif pour puits

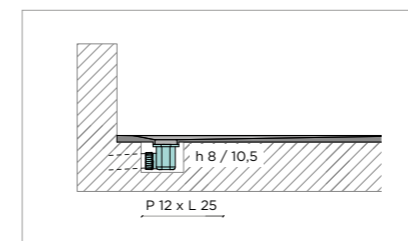

> foro per piatto a filo: h 10,5 cm

> foro per piatto in appoggio: h 8 cm

> hole for tray on the floor: h 10,5 cm

> hole for tray resting on the floor: h 8 cm

> percement pour receveur au ras du sol: h 10,5 cm

> percement pour receveur posé au sol: h 8 cm

SYNTHESIS - MISURE

misure
dimensions
dimensions

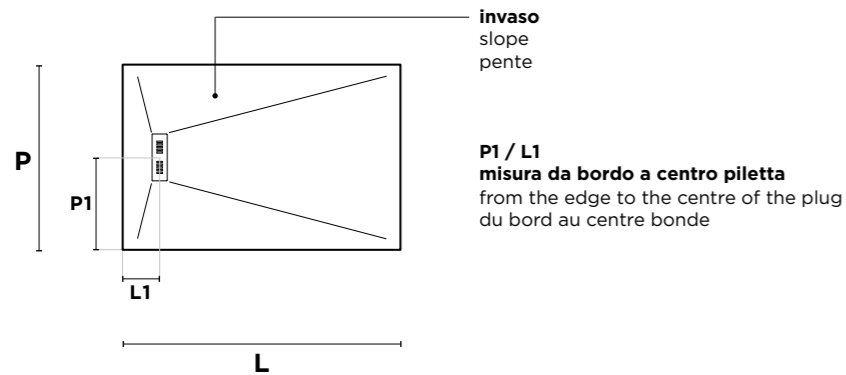

P1 / L1
misura da bordo a centro piletta
from the edge to the centre of the plug
du bord au centre bonde



Elemento disponibile per consegna rapida solo per bianco

Item available for fast delivery only in bianco finish

Article disponible pour livraison rapide, seulement en finition bianco

PROFONDITÀ (P) DEPTH PROFONDEUR	LUNGHEZZA (L) LENGTH LARGEUR	ART. ITEM ART.	P1	L1	PESO (KG) WEIGHT POIDS	PREZZO BIANCO PRICE PRIX	PREZZO COLORE PRICE PRIX
70	90	D360	35	15	20,8		
	100	D361	35	15	23,1		
	120	D362	35	15	27,7		
	140	D363	35	15	34,6		
	170	D364	15	85	41,5		
80	80	D365	40	15	20,8		
	100	D366	40	15	27,7		
	120	D367	40	15	34,5		
	140	D368	40	15	39,2		
	160	D369	15	80	43,8		
90	90	D370	45	15	28,8		
	100	D371	45	15	32,2		
	120	D372	45	15	36,9		
	140	D373	45	15	43,8		

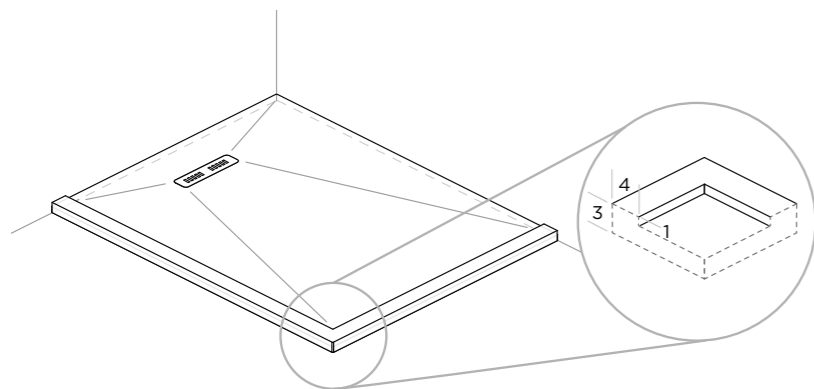

+ 2 / cm
Bordo aggiuntivo texturizzato.
L'aggiunta del bordo non comporta l'aumento delle dimensioni del piatto.
Articolo disponibile solo per bianco

+ 2 / cm
Additional texturized edge.
Adding the edge does not increase the size of the shower tray.
Item available only in bianco finish

+ 2 / cm
Bord texturisé supplémentaire.
Sa ajoute n'augmente pas la taille du receveur.
Article disponible seulement en finition bianco.

SYNTHESIS - MISURE

misure
dimensions
dimensions

P 70

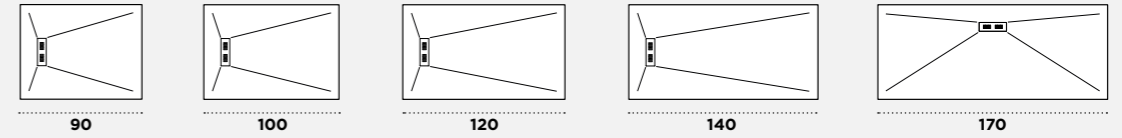

P 80

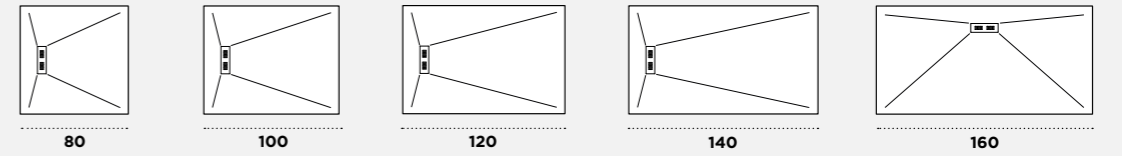

P 90

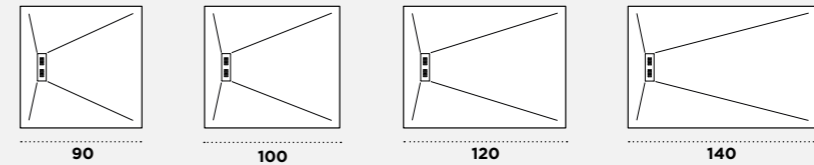

SYNTHESIS - TAGLI IN OPERA

tagli in opera
on site cuts
découpes en œuvre

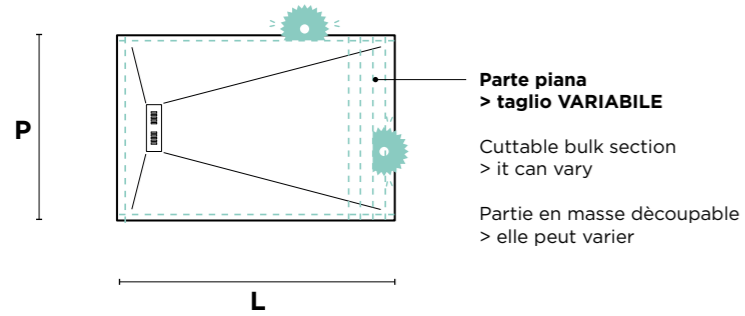

Il piatto doccia Synthesis è facilmente tagliabile in opera con un disco diamantato in quanto è tutto pieno e non alleggerito.

The Synthesis shower tray can be easily cut on site with a diamond tool as it is fully solid mass and not lightened.

Le receveur de douche Synthesis peut être facilement découpé sur place avec un outil diamanté car il est entièrement massif et non allégé.

Sezione / section / section

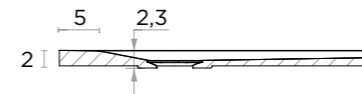

Retro piatto doccia (esempio) / Back of the shower tray (example) / Verso du receveur de douche (exemple)

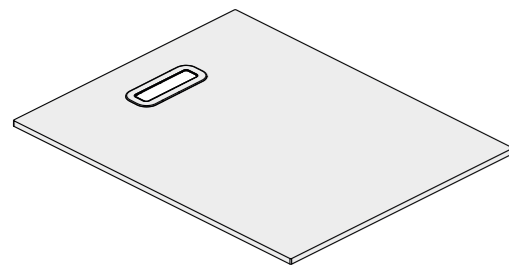

Il retro piano e la struttura del piatto piena sono caratteristiche peculiari del modello Synthesis.

The flat backside and the solid plate structure are peculiar characteristics of the Synthesis model.

Le dos et la structure en plaque solide sont des caractéristiques particulières du modèle Synthesis.

SYNTHESIS - TAGLI IN OPERA

tagli in opera
on site cuts
découpes en œuvre



TAGLIO LINEARE
Riduzione lunghezza e/o profondità. **Il lato ridotto rimane grezzo** quindi si può posizionare solo a muro.

LINEAR CUT
Length and/or depth reduction
The cut side remains raw therefore it can only be placed on the wall.

COUPE LINEAR
Réduction en longueur et/ou profondeur. **Le côté coupé reste brut**, donc il ne peut être placé que sur le mur.

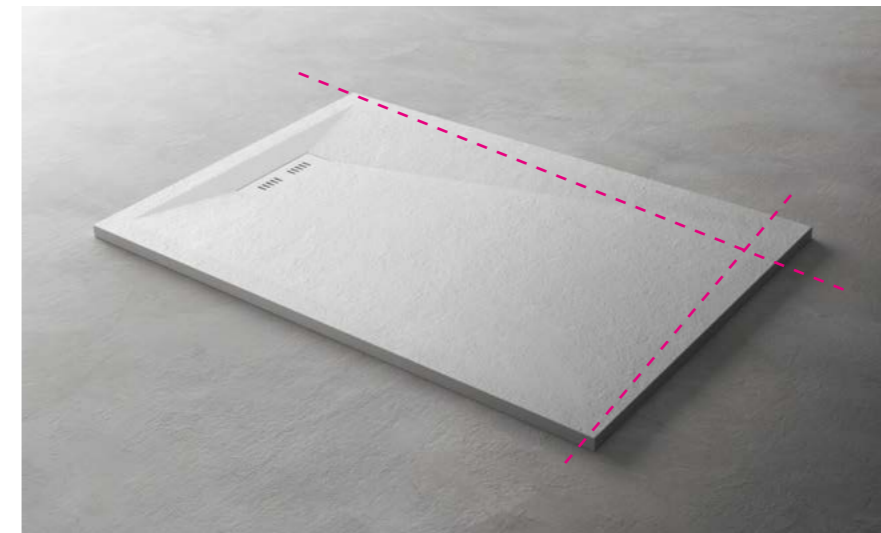

TAGLIO OBLIQUO
Taglio obliquo sul lato della lunghezza e/o profondità. **Il lato ridotto rimane grezzo** quindi si può posizionare solo a muro.

OBLIQUE CUT
Oblique cut on length and/or depth side
The cut side remains raw therefore it can only be placed on the wall.

COUPE OBLIQUE
Une coupe oblique est réalisée sur un côté du receveur (longueur ou profondeur). **Le côté coupé reste brut**, donc il ne peut être placé que sur le mur.

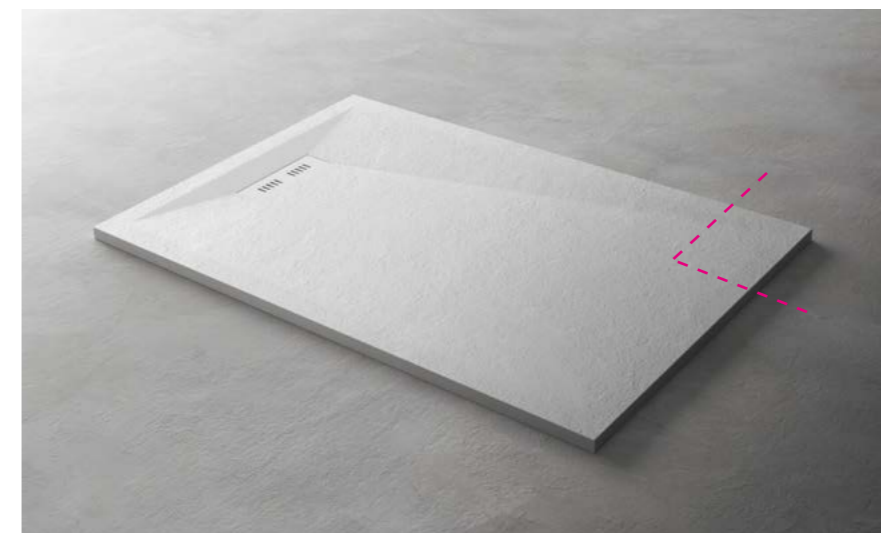

SAGOMATURA
Taglio sagomato per situazioni particolari come colonne o pilastri. **Il lato ridotto rimane grezzo** quindi si può posizionare solo a muro.

SHAPING CUT
Shaping cut for as columns or piliers.
The cut side remains raw therefore it can only be placed on the wall.

COUPE FAÇONNAGE
Une coupe façonnage est réalisée s'il y a des colonnes ou des pilotis. **Le côté coupé reste brut**, donc il ne peut être placé que sur le mur.